



WENDELBO

CASE

DESIGN BY SEBASTIAN HERKNER



TECHNICAL SPECIFICATIONS

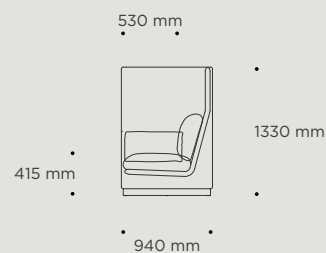

STRUCTURE INTERIOR	Frame made of FSC certified solid wood, steel and MDF, with nozag spring system.
STRUCTURE PADDING	High resilient, polyurethane foam.
SEAT CUSHION	High resilient, polyurethane foam with 50/50 feather and ball fiber top in downproof cambric divided into channels.
BACK CUSHION	50/50 feather and ball fiber in downproof cambric divided into channels.
COVER	Removable back and seat cushion cover, side cushion cover not removable.
BASE	FSC certified solid oak, black stained.
MOUNTED TABLE	Black powder coated steel. The table can be mounted in either the middle, right or left side.
MAINTENANCE	We recommend shaking and fluffing-up the cushions regularly to maintain the shape. This should be done after removing the cushions from the structure for improved air circulation. For maintenance of fabric and leather, please contact your retailer.

CASE

High back
2.5 seater

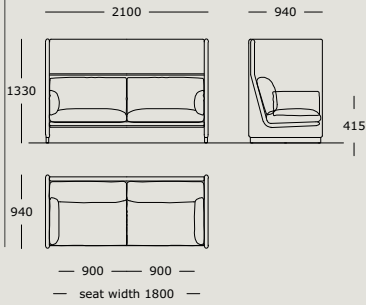

High back
2 seater

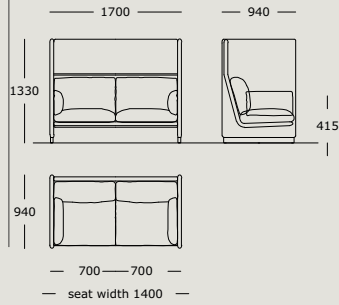

High back
1.5 seater

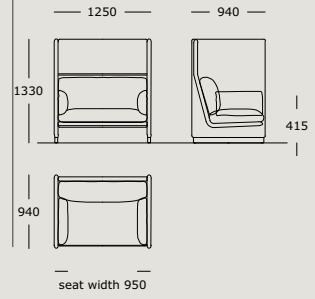

Additional:
Mounted table

